



fred066

▼ Mehr

📅 23.04.2026 - 15:11 Uhr

Hi Andreas,

ich habe gerade noch einen alternativen Weg gefunden:

Besagte Treppe markieren. In der Objektpalette wird ein Bauteil Treppenmodellierer und ein Beschriftungsbild markiert.

Nach Demarkierung nur das zuvort markierte Beschriftungsbild auswählen und entfernen.

Dann bleibt bei erneuter Markierung der Treppe nur noch der Treppenmodellierer übrig. Das Makro kann man dann auflösen:

Es erspart den Umweg, die Treppe zuvor auf ein anderes TB zu kopieren. Man kann es direkt im TB machen. Man muss nur aufpassen, dass man auch wirklich das richtige Beschriftungsbild über die Objektpalette löscht.

Sonnige Grüße

Fredo

📎 Anhänge (3)



📄 Typ: image/jpeg

📄 0-mal heruntergeladen

📄 Größe: 174,50 KiB

Treppe markieren.jpg



📄 Typ: image/jpeg

📄 0-mal heruntergeladen

📄 Größe: 161,53 KiB

Treppe demarkieren, nur...



📄 Typ: image/jpeg

📄 0-mal heruntergeladen









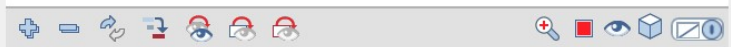









📄 Größe: 149,88 KiB

Treppe bleibt übrig.jpg



Typ Teilbild Gruppe



- ▲ Beschriftungsbild (1)  
- ▲ TB2360 (1)  
- ▲ Texte (1)  
  - ABC Beschriftungsbild  
- ▲ Treppenmodellierer (1)     
- ▲ TB2360 (1)     
- ▲ Treppen (1)     
  - Treppenmodellierer     

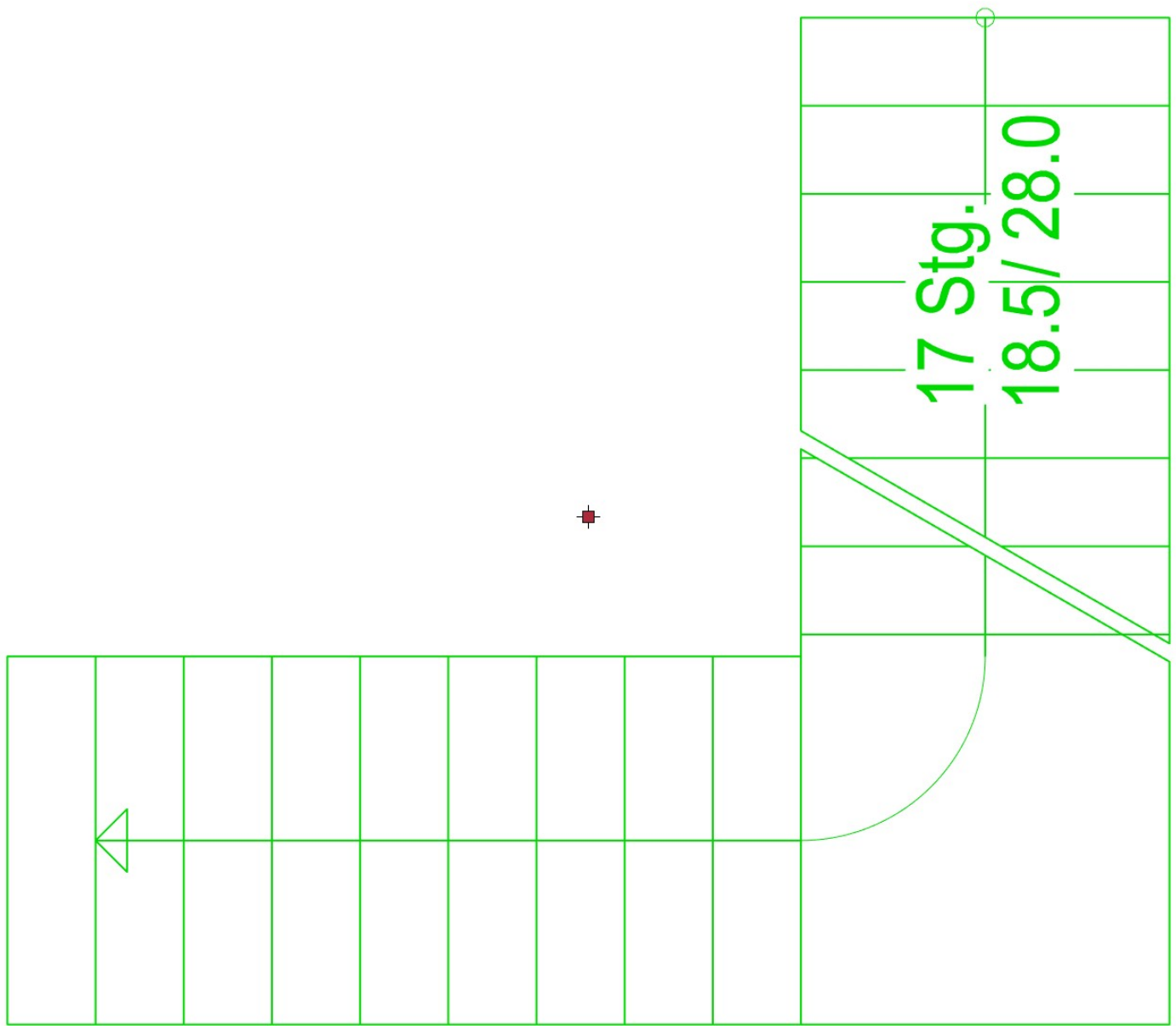

Layer

Objekte



Typ Teilbild Gruppe

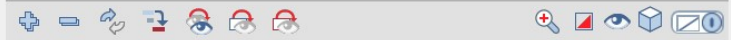

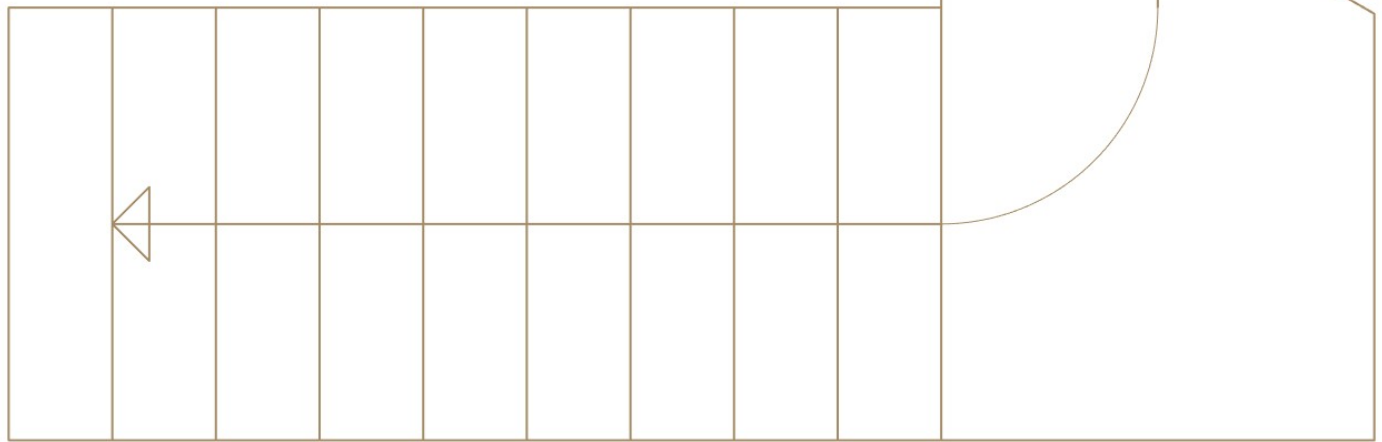

- ▲ Beschriftungsbild (1) [red square] [eye]
- ▲ TB2360 (1) [red square] [eye]
- ▲ Texte (1) [red square] [eye]
  - ABC Beschriftungsbild [red square] [eye]
- ▲ Treppenmodellierer (1) [checkbox] [eye] [3D] [lock]
- ▲ TB2360 (1) [checkbox] [eye] [3D] [lock]
- ▲ Treppen (1) [checkbox] [eye] [3D] [lock]
  - Treppenmodellierer [checkbox] [eye] [3D] [lock]













17 Stg.  
18.5/ 28.0



Layer    

Objekte  

Typ Teilbild Gruppe

- ▲ **Treppenmodellierer** (1)    
- ▲ **TB2360** (1)    
- ▲ **Treppen** (1)    
  -  Treppenmodellierer    

